

PNC	Model	Ref	Group	Level	Page	Notes
267003	AOS102EAA1	a	AOS	Level A	2...11	400V 3N 50Hz
267063	AOS102EAS1	b	AOS	Level A	2...11	400V 3N 50Hz Woolw.
267083	AOS102EAM1	c	AOS	Level A	2...11	208V 3 USA
267093	AOS102EAB1	d	AOS	Level A	2...11	240V 3 USA
267103	AOS102EAK1	e	AOS	Level A	2...11	400V 3N 50Hz UK
267113	AOS102EAT1	f	AOS	Level A	2...11	400V 3N China
268003	AOS102EBA1	g	AOS	Level B	2...11	400V 3N 50Hz
268103	AOS102EBK1	h	AOS	Level B	2...11	400V 3N 50Hz UK
269003	AOS102ECA1	i	AOS	Level C	2...11	400V 3N 50Hz
269083	AOS102ECM1	l	AOS	Level C	2...11	208V 3 USA
269093	AOS102ECB1	m	AOS	Level C	2...11	240V 3 USA
237003	FCZ102EAA	n	FCZ	Level A	2...11	400V 3N 50Hz
238003	FCZ102EBA	o	FCZ	Level B	2...11	400V 3N 50Hz
239003	FCZ102ECA	p	FCZ	Level C	2...11	400V 3N 50Hz



PLATON SERVICE
8 (800) 500-34-41
www.platonservice.com

Pag	Index	Indice	Note
2	Oven cabinet and door.	Cella forno e porta	
3	Water system	Impianto idraulico	
4	Boiler	Boiler	
5	Electrical components	Componenti elettrici	
6	Accessories	Accessori	
7...10	Spare parts list	Lista ricambi	

Brand/Marchio: All
Factory code: 9PDD

From sr. Nr/ Da Ser. Nr.: 917
From status level / Da scatto: 04

Page: 1

Ed. 2010 04

Doc. Nr.: **3 - 13 604**

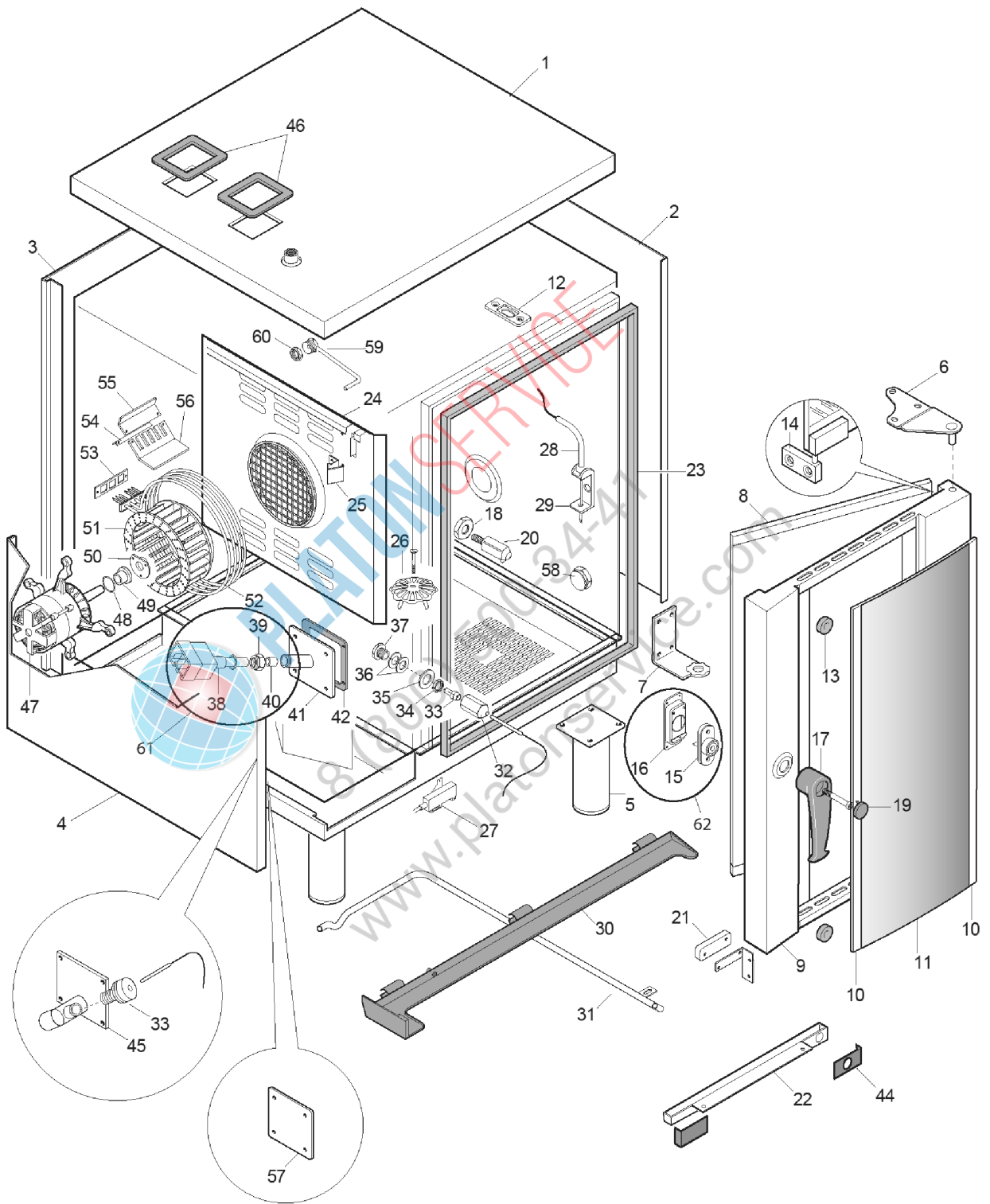

??????		268003									
??????		3-13604		???????? 2		Oven cabinet and door.					
.		Alias		S			.			(Euro)	
0001	0C6178	0530891400						LID; ONE 062-102E		220,30	
0002	0C6176	0530891100						RIGHT SIDE; ONE 102		170,50	
0003	0C6191	0530892800						BACK PANEL; ONE 102		122,80	
0004	0C6197	0530893400						LEFT SIDE; ONE 102		156,30	
0005	0C4892	0831850900		S				FOOT; 2"		11,46	
0006	0C4234	0806847803		S				PLATE; ASSY,UPPER AOSQ		22,43	
0007	0C4235	0806861600	0C9574					PLATE; ASSY.LOWER 6-10 AOSQ			
0008	0C4504	0873870002		S				DOOR GLASS; ASSY; INT. LW 102 AOSQ		114,70	
0009	0C4505	0878864307			D			DOOR ASSEMBLY; AOSQ 10 2/1		765,00	
0010	0C4476	0806859302		S				PROFILE; EST.LW10 AOSQ		34,92	
0011	0C4503	0574817303						CURVED GLASS; EST.LW102 OSQ	For AOS Version	350,20	
0011	0C4944	0574818601						DOOR GLASS; EXT; ONE 102	For FCZ Version	111,70	
0011	0C5808	0574818002						CURVED GLASS; B/E LW 102 "WOOLWORTHS"	For WOOLW Version	239,50	
0012	0C4088	0543839700		S				GASKET		8,13	
0013	006976	0543828001		S				SHOCK ABSORBER		4,33	
0014	007007	0806822000		S				HINGE		16,36	
0015	0C4089	0835871801	0C4477					LOCKING MECHANISM			
0016	0C4237	0510824200		S				SUPPORT; LW06-10 AOSQ		18,98	
0017	0C4090	0548871500		S				HANDLE; LW06-10 AOSQ		13,09	
0018	0C4238	0516896400		S				NUT; FOR CATCH AOSQ		11,72	
0019	0C4091	0546822600		S				PLUG; LW06-10 AOSQ		6,76	
0020	0C4092	0806859900		S				CATCH		35,42	
0021	049627	0699603700		S				MAGNET		9,82	
0022	0C4292	0528869601						BOWL; LW102 AOSQ		62,83	
0023	0C1887	0543835000		S				DOOR GASKET; 725X630MM		93,99	
0024	0C4620	0831847104						SUCTION WALL; AOSQ 102		276,10	
0025	0C3423	0518807301						SPRING; SUCTION WALL		19,63	
0026	0C2769	0518808700						BOTTOM STRAINER		13,26	
0027	049621	0654600000		S	C	+		REED SWITCH		15,00	
0028	0C4240	0831831001		S				CORE PROBE; AOSQ T.C.MULTIPOINT	For Level A	226,30	
0028	0C4241	0831830702		S				CORE PROBE; SINGLE POINT AOSQ	For Level B, C	128,90	
0029	0C1505	0527865201						SUPPORT		7,29	
0030	0C4298	0856814100		S				DRIP TRAY; 10 2/1 AOSQ		20,29	
0031	0C4293	0806858901						HOSE		42,53	
0032	006991	0516855300						NUT		22,43	
0033	0C4872	0543842600		S				PLUG; FOR SENSOR		7,29	

??????		268003									
??????		3-13604		???????? 2		Oven cabinet and door.					
.		Alias		S			.				(Euro)
0034	020997	0214105101		S				LOCK NUT			1,25
0035	002701	0516809301		S				INSULATOR			3,59
0036	002624	0543816300		S				GASKET; SET 50 PCS			24,16
0037	002623	0516809400		S				PIPE FITTING			10,04
0038	006995	0830891200	0C6465	S		+		LAMBDA PROBE	For Level A		
0039	050670	0214111412		S				NUT; M20X1,5	For Level A		9,94
0040	050682	0215170716		S	C			DOUBLE CONE; ØI=12MM	For Level A		2,02
0041	0C4244	0806857201		S				FLANGE; FOR LAMBDA SONDE	For Level A		40,09
0042	0C4093	0543838300		S				GASKET			11,09
0044	0C4094	0543841300						GASKET			11,61
0045	0C4245	0806856200						SHAPED TUBE; BY-PASS AOS Q 6-10	For Level B, C		114,30
0046	0C1194	0543832100		S				GASKET			7,92
0047	0C6563	0611810000		S				MOTOR; 200-240V/750W			360,30
0047	0C6704	0611400500		S				MOTOR; 200V/240V-750W 50/60HZ	For Lev.A 60Hz USA		350,20
0048	002873	0543816700		S				O-RING; ØI=MM.28,17X3,53			2,43
0049	002699	0516808902		S				BEARING; FOR MOTOR SHAFT			20,50
0050	0C4138	0538815400		S				FLANGE			5,81
0051	0C1172	0831804901	0C6464					FAN BLADE; ASS.			
0052	0C1173	0617828000	0C6502					HEATING ELEMENT; 400V 8KW	For 400V Version		
0052	0C2241	0617829300						HEATING ELEMENT; 8KW 208V USA	For 208V Version		153,30
0052	0C2242	0617829900						HEATING ELEMENT; 8KW 240V USA	For 240V Version		181,70
0053	002689	0543816501		S				HEATING ELEMENT GASKET			26,09
0054	006253	0503897402		S				ANGLE			9,19
0055	0C1175	0527856600		S				STIRRUP			20,10
0056	0C1174	0527856500		S				SUPPORT			19,59
0057	0C4857	0527898900		S				PLAQUE	for Level C		6,33
0058	000000										
0059	0C4976	0856828501						WATER PIPE; ONE 102/202 LIV.C	for Level C		42,43
0060	0C6228	0516887101		S				PIPE FITTING	for Level C		18,88
0061	000000										
0062	000000										

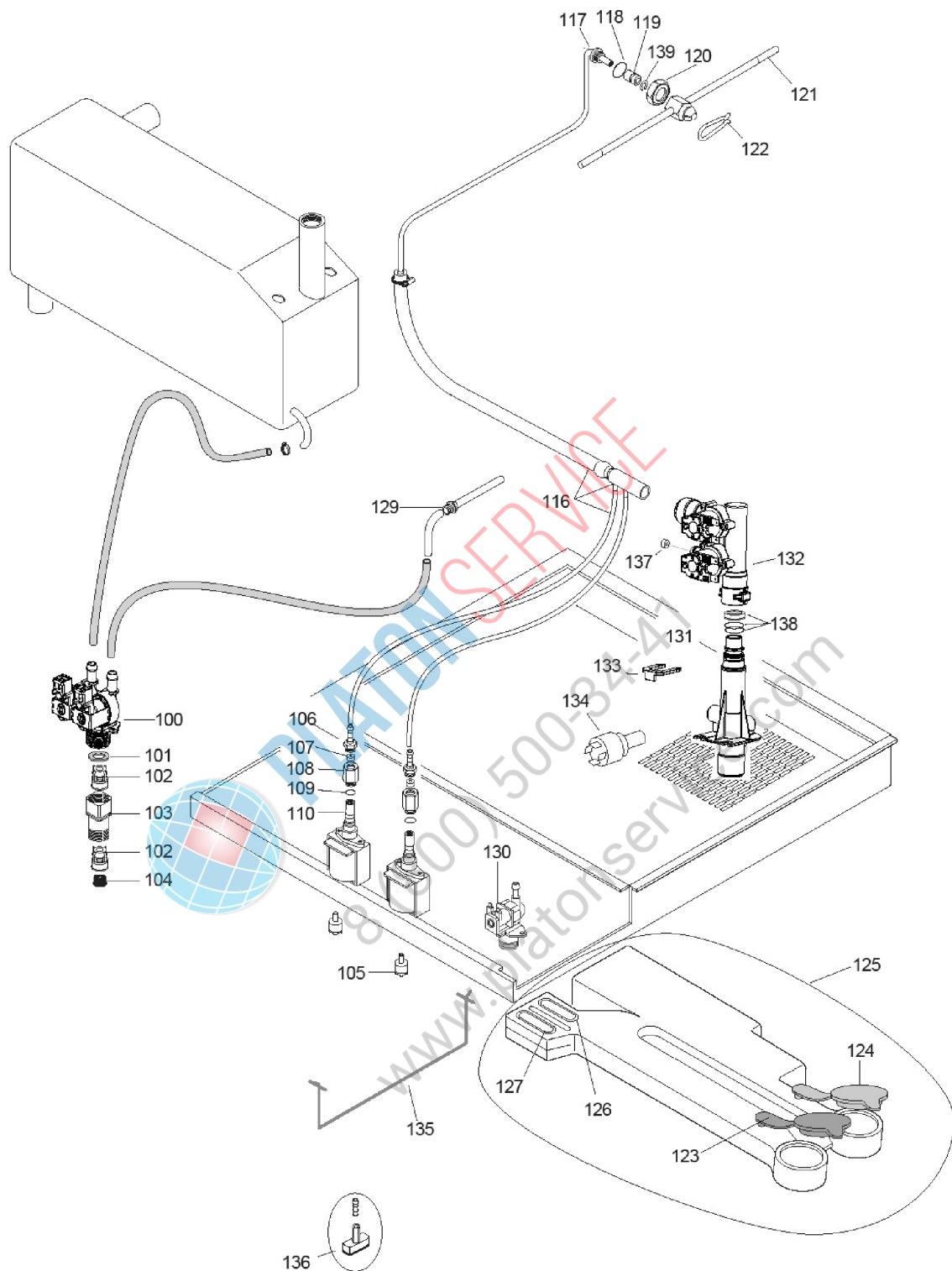

??????	268003									
??????	3-13604		???????? 3				Water system			
.		Alias		S			.			(Euro)
0100	0C5517	0696808300		S	C			WATER SOLENOID VALVE; 2 VIE/180 5/L MIN	for Level A,B	33,36
0101	0C4096	0543840600		S				FILTER GASKET	for Level A,B	1,27
0102	0C2312	0549801800		S				NONRETURN VALVE	for Level A,B	5,86
0103	0C2313	0516879400		S				PIPE FITTING	for Level A,B	29,54
0104	000000									
0105	0C1155	0831811400		S				FILTER	for Level A,C	15,97
0106	0C4198	0516896101		S				RUBBER HOLDER; G1/4" DIA 4 MM	for Level A,C	13,30
0107	0C1117	0544809000		S				NONRETURN VALVE	for Level A,C	6,90
0108	0C1116	0516871900		S				FITTING; RINSE AND DETERGENT PUMPS	for Level A,C	10,29
0109	0C1935	0543832300		S				O-RING; ØI=6,75X1,78 MM	for Level A,C	1,02
0110	000000	0633832900							For WOOLW Ver.	
0110	000000	0878400D01							For WOOLW Ver.	
0110	0C2341	0680801201	0C6947					PUMP	for Level A, C 50 Hz	
0110	0C2342	0680801301		S				ELECTRIC PUMP; 120V 60HZ 32W	for Level A, C 60 Hz	60,39
0110	0C4438	0856815300						LEVEL SENSOR; DETERGENT; "WOOLWORTH"	For WOOLW Ver.	96,43
0110	0C4439	0856815400						LEVEL SENSOR; RINSE AID; "WOOLWORTH"	For WOOLW Ver.	96,43
0116	0C6203	0805400300		S				MANIFOLD; ASSY; ONE C.S.062-102	for Level A,C	33,39
0117	0C5430	0806871200						PIPE; ASSY	for Level A,C	42,63
0118	0C4201	0543841400		S				GASKET; 17X22X1,5	for Level A,C	2,53
0119	0C4467	0516898301		S				BUSHING; FCS 6	for Level A,C	10,77
0120	0C4202	0516896000		S				LOCK NUT; INOX M16X1.5X6H	for Level A,C	5,33
0121	0C5503	0806873900	0C8317					WASH ARM; ASSY; L=422MM	for Level A,C	
0122	007026	0518807100		S				SPRING	for Level A,C	14,25
0123	0C1151	0544808100		S				PLUG BLU	for Level A,C	3,08
0124	0C1152	0544808200		S				RED CAP	for Level A,C	2,76
0125	0C4426	0544808001		S				RESERVOIR; ASSY	for Level A,C	52,07
0126	0C1154	0544808900		S				WALL RED	for Level A,C	4,13
0127	0C1153	0544808400		S				WALL BLU	for Level A,C	4,13
0129	007075	0H22982800						PIPE	for Level A, B	29,84
0129	0C4978	0856828700						WATER PIPE; ONE 102-202 LIV.C	for Level C	28,93
0130	0C3254	0696805700		S	C			SOLENOID VALVE; 1 WAY; 180°;230V 50-60HZ	for Level B	13,98
0130	0C5515	0696808200		S				WATER SOLENOID VALVE; 1 VIA/180°	for Level C	15,86
0131	000000	0835400000							for 60Hz Version	
0131	0C6370	0831857200		S				MANIFOLD; ASSY		42,43
0132	0C6373	0696400100			D	PDD2012-17		WATER DISTRIBUTOR; 1U-230V 1U-110V 50/60	for 60 Hz Version	70,04
0132	0C6374	0696808600			D	PDD2012-17		WATER DISTRIBUTOR; 2 OUTPUP; 230V 50/60H	for Level A	100,30

??????	268003									
??????	3-13604		???????? 3				Water system			
.		Alias		S		.				(Euro)
0132	0C6406	0696400300			D	PDD2012-17	WATER DISTRIBUTOR; 1U.230V- 50/60HZ	for Level C		55,52
0133	0C6222	0546825100		S			SAFETY DEVICE			6,26
0134	0C6217	0646817200		S			PRESSURE SWITCH; GP600	for Level A,C		33,50
0135	0C5426	0513805000		S			STIRRUP	for Level A,C		14,15
0136	0C6201	0546824100		S			PIVOT	for Level A,C		1,02
0137	0C6375			S		Kit	FLOW REDUCER; KIT 4PCS	for Level A,C		11,67
0138	0C6377			S		Kit	O-RING WITH BUSH; KIT	for Level A,C		15,60
0139	0C6421	0219035015		S			SPRING RING	for Level A,C		1,02



PLATON SERVICE

8 (800) 500-34-41

www.platonservice.com

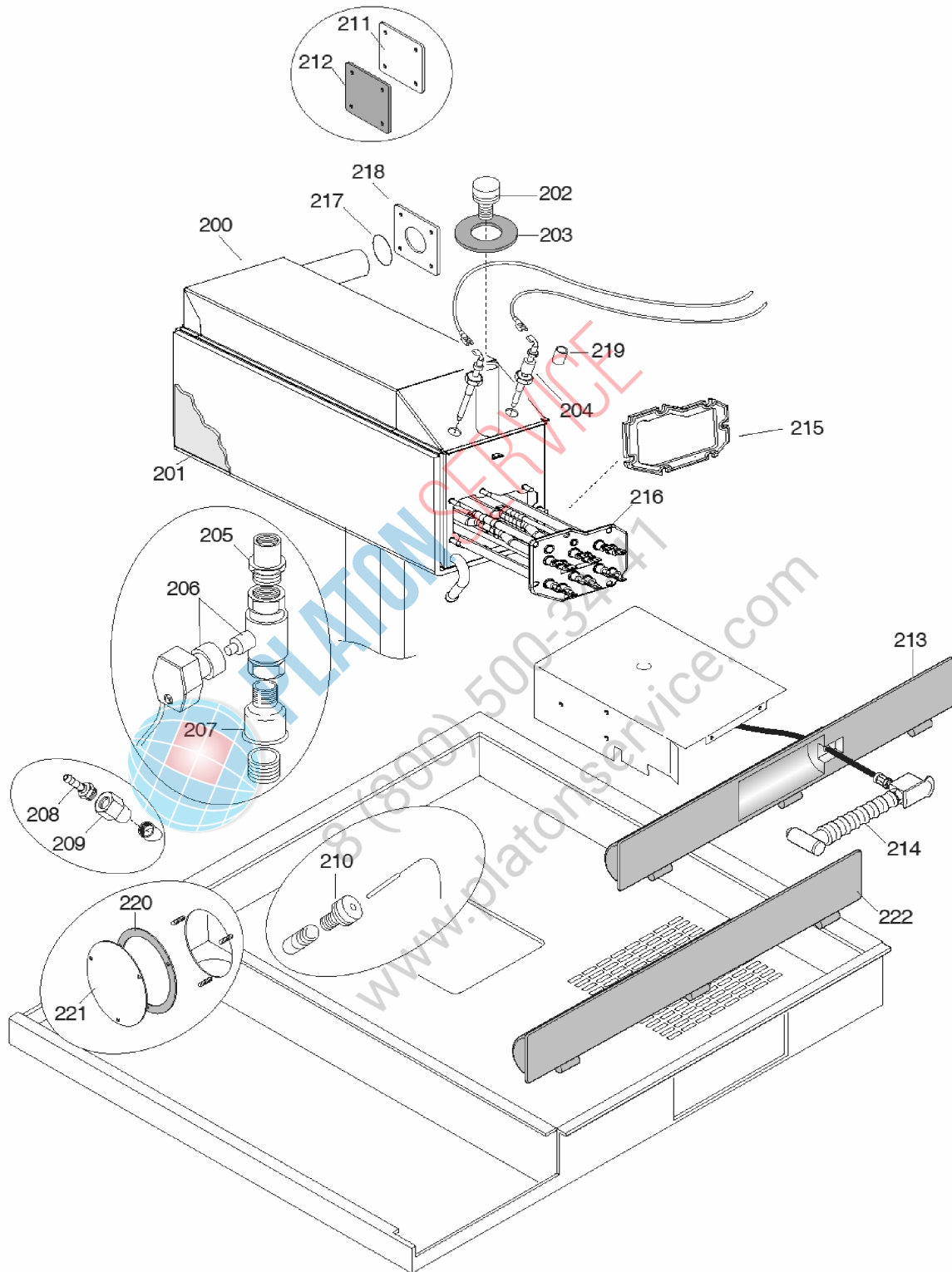

??????	268003								
??????	3-13604		???????? 4	Boiler					
.		Alias		S			.		(Euro)
0200	0C4351	0831844600	0C5852					BOILER; ASSY; AOS-Q 10 2/1 - 20 1/1 ELT.	
0200	0C5852	0831855600				+		BOILER; ASSY; 102-201 ELT. VERS.UK	For UK Version 739,00
0201	0C5837	056980700						BOILER INSULATION; ELT ONE 102 - 201	58,26
0202	002692	0543816601		S				CAP; DESCALING LOAD IN THE BOILER	6,76
0203	0C5834	0543844800		S				GASKET; BOILER HEATING ELEMENT	19,69
0204	0C1201	0830890600		S				LEVEL PROBE; ASSY	32,99
0205	007117	0516809501		S				CONNECTION	15,81
0206	0C0882	0696804201		S				MOTOR-OPERATED VALVE; 3/4" 230V 50/60HZ	144,10
0206	0C5518	0696808500		S				BALL VALVE; 3/4' USA 240V 50/60HZ	For 60Hz Version 145,10
0207	0C1063	0516868600	0C8412					PIPE FITTING	
0208	0C5564	0510828000		S				RUBBER HOLDER; 1/4"; FOR TUBE DIA.10MM	5,33
0209	0C4099	0516879600		S				NOZZLE; 1/4"FD3.5-3/8"M	18,88
0210	0C4872	0543842600		S				PLUG; FOR SENSOR	7,29
0211	0C4856	0527898700		S				FLANGE	For Level C 6,76
0212	0C4963	0543842800		S				GASKET; FOR BOILER	For Level C 19,54
0213	0C4533	0546818503						FRONT PANEL; LOWER; 10 2/1 AOSQ	79,07
0214	0C4248	0873881200		S				SHOWER UNIT; AOSQ	257,80
0215	0C5834	0543844800		S				GASKET; BOILER HEATING ELEMENT	19,69
0216	0C5822	0617837200						HEATING ELEMENT; 208V-20000W	For 208V Version 288,30
0216	0C5841	0617836500		S				HEATING ELEMENT; 400V-24000W	For 400V Version 211,10
0216	0C5841	0617837800		S				HEATING ELEMENT; 400V-24000W	For 240V Version 211,10
0217	002874	0543816800		S				O-RING; ØI=31,34X3,53 MM	3,48
0218	0C4821	0527898600		S				FLANGE	7,39
0219	055347	0515857001		S				SPACER; H=11,5MM	5,81
0220	0C3442	0543839600	0C7033					GASKET	
0221	0C3443	0J89061403						WASHER; FOR DOOR	15,84
0222	0C4966	0546821501			D			FRONT PANEL; NEUTRAL; 062-102	For Level B 20,10

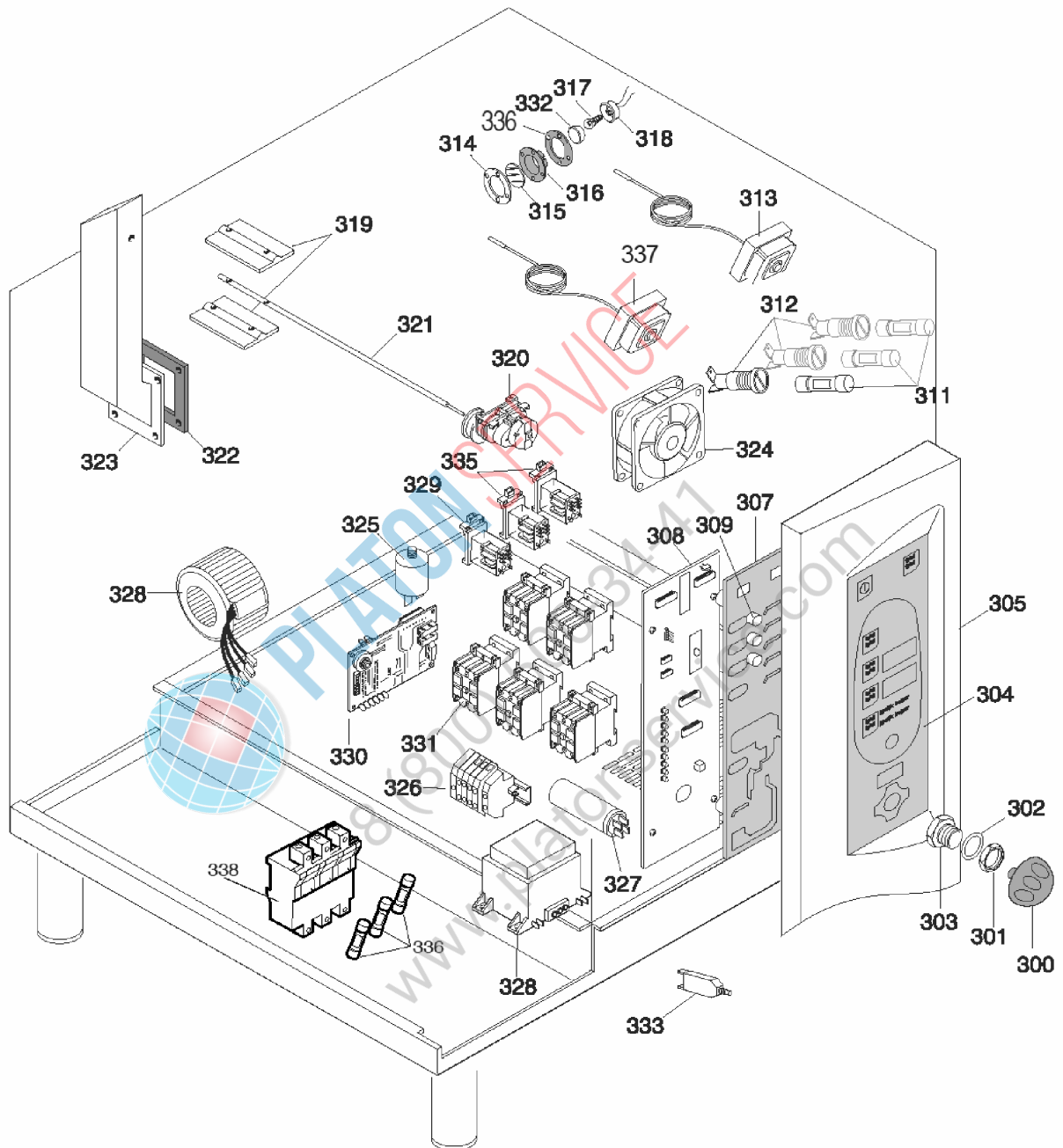

??????	268003									
??????	3-13604		???????? 5				Electrical components			
.		Alias		S			.			(Euro)
0300	0C5600	0806874001	0C4875						KNOB	
0301	051263	0214114900		S					LOCK NUT	3,80
0302	002727	0508836400		S					WASHER	1,02
0303	002662	0516807301		S					BUSH	6,02
0304	007058	0675838902							MEMBRANE	for Level B AOS Ver.
0304	0C4947	0675854900							ADHESIVE MEMBRANE; ONE; LIV.A	for Level A FCZ Ver.
0304	0C4948	0675855001							ADHESIVE MEMBRANE; ONE; LIV.B	for Level B FCZ Ver.
0304	0C4949	0675855102							ADHESIVE MEMBRANE; ONE; LIV.C	for Level C FCZ Ver.
0304	0C5067	0675854800							ADHESIVE MEMBRANE	for Level C AOS Ver.
0304	0C5614	0675838204							ADHESIVE MEMBRANE	for Level A AOS Ver.
0304	0C5614	0675838204							ADHESIVE MEMBRANE	For WOOLW
0305	0C4295	0873879501							CONTROL PANEL; LW102 LIV.A AOSQ	for Level A AOS Ver.
0305	0C4302	0873880300							CONTROL PANEL; LW102 LIV.B AOSQ	for Level B AOS Ver.
0305	0C4895	0873894300							CONTROL PANEL; ASSY; AOSQ 102 LIV.C	for Level C AOS Ver.
0305	0C4904	0873896202							CONTROL PANEL; ONE 102 LIV.A	for Level A FCZ Ver.
0305	0C4905	0873896302							CONTROL PANEL; ONE 102 LIV.B	for Level B FCZ Ver.
0305	0C4906	0873896402							CONTROL PANEL; ONE 102 LIV.B	for Level C FCZ Ver.
0307	0C0041	0675838802		S					USER INTERFACE; LIV B	for Level B
0307	0C0043	0675837902		S					USER INTERFACE BOARD; COPUI20-A; LEV.A	for Level A
0307	0C4891	0675854600			D		PDD2012-16		USER INTERFACE BOARD	for Level C
0307	0C6160	0675859701							USER INTERFACE BOARD; COPUI20-J	for Jap, Cina - Level A
0308	0C0042	0675837808		S					POWER BOARD; COP20-A; LIV A/B/C LW	for Level A
0308	0C6159	0675859201							POWER BOARD; COP20-J SW4.10	for Jap, Cina Version
0309	0C5833	0546824600							BUTTON EXTENSION; L=7,4MM	1,02
0311	058869	0652800701		S					FUSE; 10A	For 400V; 230V
0311	0C1480	0652803300		S					FUSE; 5*20 6,3A T; USA	For 208V; 240V
0311	0C2301	0652803900		S					FUSE; OMEGA 800MA (COD. ST22180)	For 400V; 230V
0311	0C5431	0652803801		S					TIME-LAG FUSE; 5X20 T10A UL/CSA	For 208V; 240V Liv. C
0312	0F0031	0652802100		S					FUSE CARRIER	For 400V; 230V
0313	006314	0646810802		S					SAFETY THERMOSTAT; 338 C	For 60Hz Version
0313	007042	0646812200		S	C				SAFETY THERMOSTAT; 357°C	93,15
0314	002628	0508840801		S					FLANGE	4,01
0315	002627	0574804900		S			+		LAMP GLASS	10,24
0316	002626	0543817202		S			+		LAMP HOLDER GASKET	15,39
0317	0C4396	0660808300	0C9877	S	C				HALOGEN LAMP; 12V-10W 300GR C.	

??????	268003									
??????	3-13604		???????? 5				Electrical components			
.		Alias		S			.			(Euro)
0318	0C1200	0660807000		S			LAMP HOLDER			25,38
0319	0C1169	0538804000					THROTTLE			19,89
0320	0C5501	0680802300	0C0883				GEARMOTOR; 230V-50HZ			
0320	0C5502	0680802400	0C1479				GEARMOTOR; 24V-60HZ; USA	For 60Hz Version		
0321	0C5523	0856832500					STEM; 10-20 2/1			18,98
0322	0C1168	0543832200					GASKET			31,57
0323	0C1219	0831806402					PIPE			69,53
0324	0C4106	0624811000		S			FAN; 220/240V 50/60HZ			37,76
0325	049303	0694605400		S			RADIO INTERFERENCE FILTER; 250V 50/60HZ			23,55
0326	0C4820	0639812400					TERMINAL BOARD; 35MMQ	For 60Hz Version		40,40
0326	0F0112	0639808600		S			TERMINAL BOARD			28,62
0327	0C1186	0694800700		S			CONDENSER; 31.5 MF			19,18
0328	0C0886	0624807901		S			TRANSFORMER;480VA 12/24/120/208/220/240	For 60Hz Version		212,10
0328	0C6400	0624400100		S		Kit	TRANSFORMER; KIT			76,73
0329	058857	0648803001		S			RELAY			25,12
0329	088267	0648722900		S			RELAY; COIL 200-240VAC	For 60Hz Version		39,18
0330	007047	0624807002		S			POWER SUPPLY BOARD; LAMBDA PROBE			145,10
0331	006879	0648807400		S	C		CONTACTOR; 220-240V 50HZ/240-264V 60HZ	For 60 Hz		37,68
0331	007080	0648807700		S	C		CONTACTOR; 220-240V 50HZ/240-264 60HZ			79,89
0331	088477	0648807300		S	C		CONTACTOR; 220-240V 50HZ/240-264V 60HZ			28,84
0331	0C2244	0648808400		S	C		CONTACTOR; 220-240V 50HZ/240-264V 60HZ	For 60 Hz		159,80
0331	0L0355	0648613200		S	C	+	CONTACTOR; 220-240V 50HZ/240-264V 60HZ			68,73
0332	0C4459	0509803900		S			LAMP CAP			5,91
0333	000000									
0335	056466	0648802601		S			RELAY	For 60Hz Version		26,29
0336	0C2245	0652803600		S			FUSE; OMEGA 22*58 80A (COD. FF258380)	For 60Hz Version		43,75
0337	0C2983	0646814900		S	C		OVERTEMPERATURE LIMITER; 140GR 3P	For Level A, B		82,80
0338	000000	0675859501						for Cina Version		
0338	0C1487	0652803400					FUSE CARRIER	For 60Hz Version		117,70

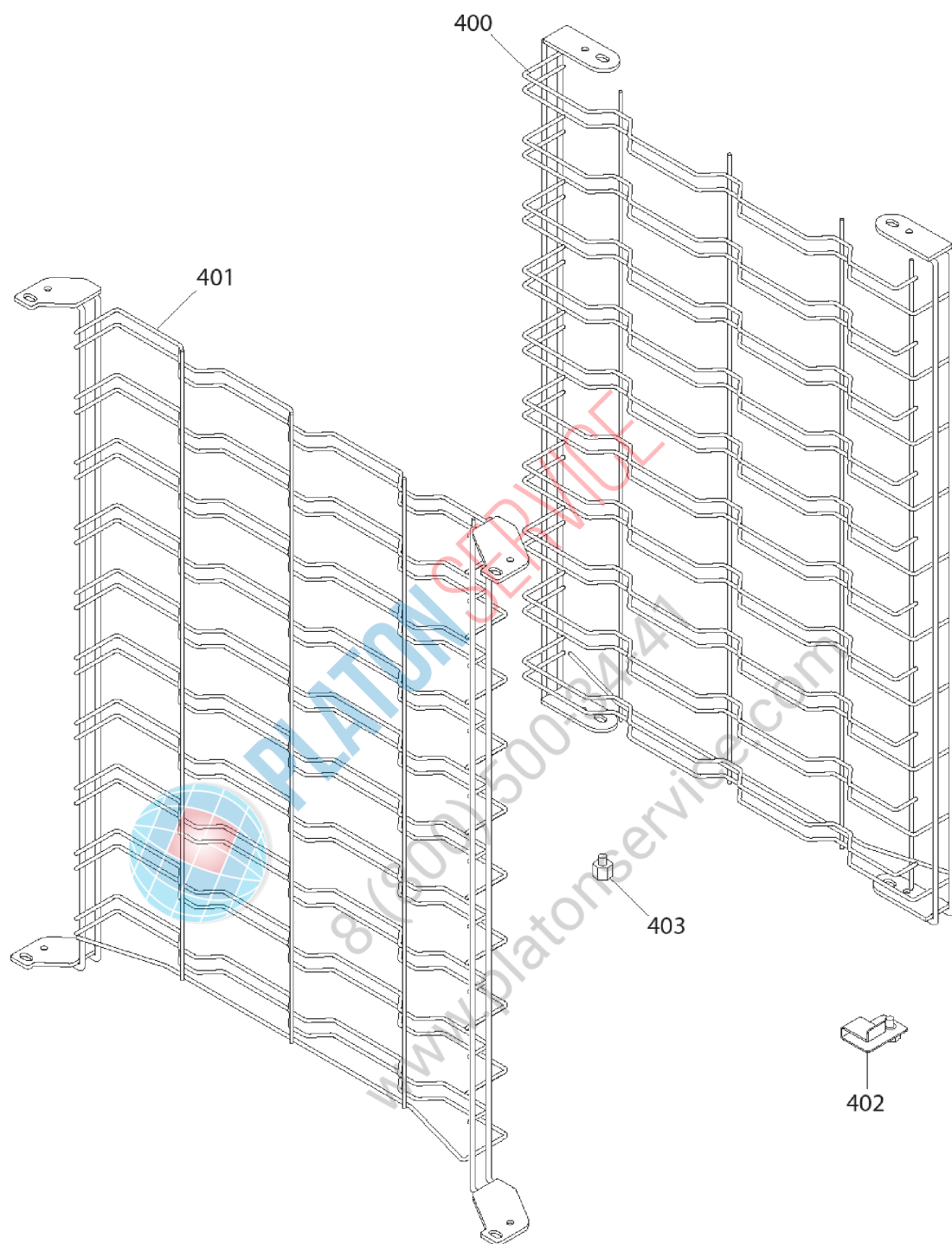

??????	268003									
??????	3-13604	???????? 6	Accessories							
.		Alias		S			.			(Euro)
0400	0C6016	0831849800						TRAY SUPPORT; RIGHT; ONE 102	For P 60 Version	151,20
0401	0C6017	0831849900						TRAY SUPPORT; LEFT; ONE 102	For P 60 Version	156,30
0402	0C4961	0806872800		S				SUPPORT		27,51
0403	0C5620	0511828100		S				BAKING PAN SUPPORT		11,41



PLATON SERVICE

8 (800) 500-34-47

www.platonservice.com